

Joist Hangers Structural Fixings Guide

Joist Hangers are designed to be used where a strong rigid joint is required between members butting together at 90 degrees, e.g. floor joist to beam, truss or rafter to beam/bearer.

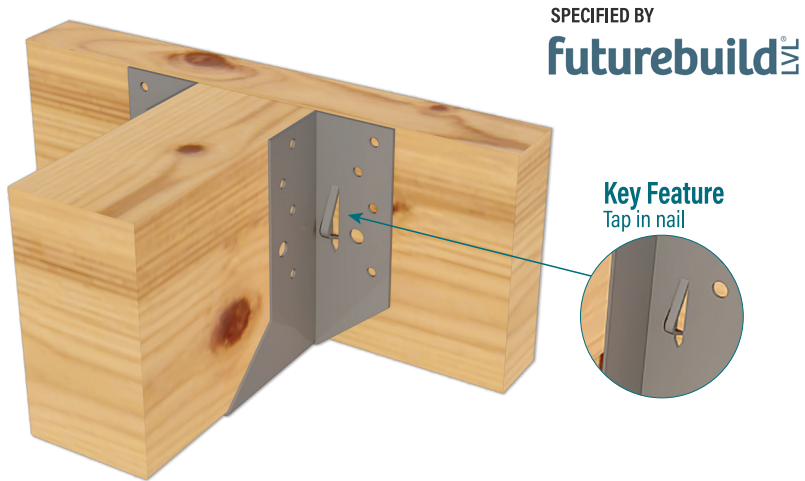

Materials:

1.00mm G300 Z275 Galvanised Steel

1.0mm 304 Stainless Steel

Joist Hanger	
Size	Description
47 x 90mm	For use on gauged 47mm wide timber up to 150mm deep.
47 x 120mm	Suitable for gauged 47mm wide timber up to 200mm deep.
47 x 190mm	For gauged 47mm wide timber up to 300mm deep.
95 x 165mm	For used on gauged 94mm wide timber or double joists/trusses. (Joist Hangers to suit 100mm thick (nominal) timber).

All sizes are available in 304 Stainless Steel.

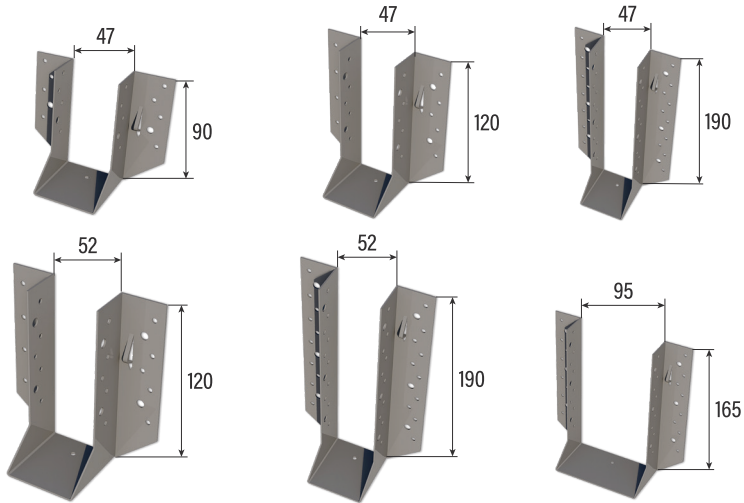

Materials:

- 1.0mm G300 Z275 Galvanised Steel
- 1.0mm 304 Stainless Steel

IMPORTANT NOTE

For other load conditions, refer to the Characteristic Load Table below for correct product selection and nailing or screw fixing. In some cases it may be necessary to fully nail or screw fix the Joist Hanger.

■ Gravitational ■ Uplift

Joist Hanger							
Code	Size (mm)	Nails per Flange	Load (kN)		Screws per Flange	Load (kN)	
JH4790 & JHSS4790	47 x 90	3	9.0	6.0	1 (+ 1 nail)	7.0	4.7
JH47120* & JHSS47120	47 x 120	5	15.0	10.0	2	14.0	12.0
JH47190* & JHSS47190	47 x 190	9	27.0	18.0	3	21.0	18.0
JH95165 & JHSS95165	95 x 165	8	24.0	16.0	3	21.0	18.0

Nails 38 x 3.33mm or Screws 14g x 35mm Hex Head Type 17
 *Available in 52mm for rough sawn timber.

Characteristic Strengths have been derived from testing conducted by BRANZ (ST-18222) in accordance with EMI as specified in NZS3604:2011.

NOTE

For roof trusses, Joist Hangers shall be fully nailed or screw fixed.

I-Joist Hangers Structural Fixings Guide

The I-Joist Hanger has been developed to provide an effective method of fixing timber I-Joist to supporting timber beams.

SPECIFIED BY

futurebuild [®] _{LM}

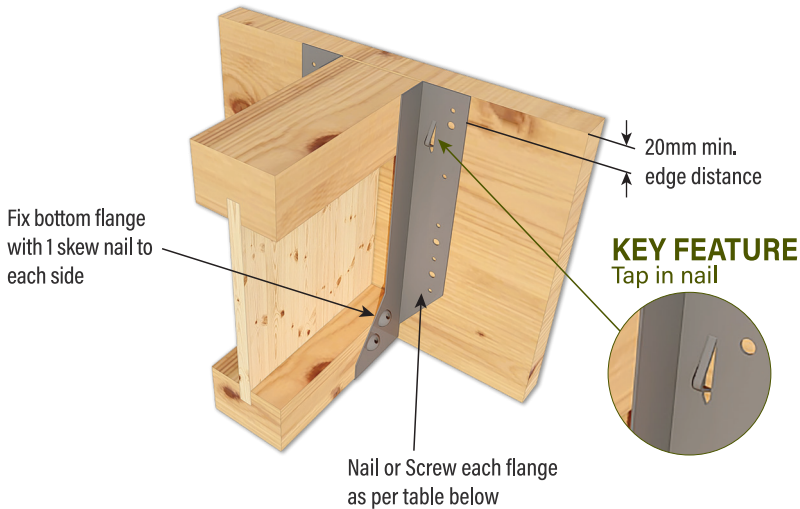

- Fix I-Joist Hanger with 38 x 3.33mm galvanised nails to face of supporting beam through small holes (4mm dia.). Alternatively use. Type 17 - 14g x 35mm screws in the larger holes (6mm dia.). Refer to table for quantity of nails/screws required.
- Fix bottom I-Joist flange using either 2/ 30 x 3.15 or 2/ 38 x 3.33 galvanised nails. Select one dimple each side of the I-Joist which will allow the nail to be driven fully home at a 45° angle.

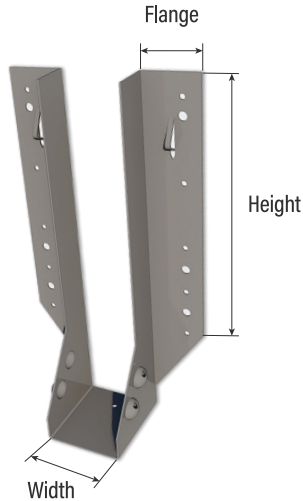

Materials:

1.2mm G300 Z275 Galvanised Steel

I-Joist Hanger		Gravitational			
Code	Size (mm)	Nails per Flange	Load (kN)	Screws per Flange	Load (kN)
JHIB24050	240 x 50	5	12.0	3	18.0
JHIB24065	240 x 65	5	12.0	3	18.0
JHIB24090	240 x 90	5	12.0	3	18.0
JHIB30050	300 x 50	6	14.4	4	24.0
JHIB30065	300 x 65	6	14.4	4	24.0
JHIB30090	300 x 90	6	14.4	4	24.0
JHIB36065	360 x 65	7	16.8	5	24.0
JHIB36090	360 x 90	7	16.8	5	24.0
JHIB40090	400 x 90	8	19.2	6	24.0

- Nails 38 x 3.33mm or Screws 14g x 35mm Hex Head Type 17
- Fix bottom flange using 1 nail through each side at 45° angle or alternative fixing hole on underside of joist hanger. (Engineer to specify)

Characteristic Strengths have been derived from testing conducted by **BRANZ (ST-18222)** in accordance with EMI as specified in **NZS3604:2011**.

Concealed Purlin Cleat (CPC)

ECKO Concealed Purlin Cleats (CPC) provide an economical rigid connection frequently used to secure trusses/rafters to beams and wall plates.

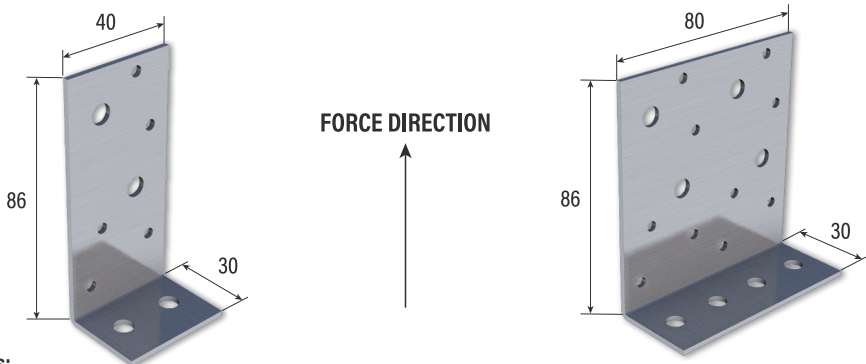

Materials:

- 2.0mm G300 Z275 Galvanised Steel
- 2.0mm 304 Stainless Steel

Code	Nail Fixing		Screw Fixing	
	Nails Top Flange	Load (kN)	Screws Top Flange	Load (kN)
BCPC40-100 / BCPC40SS-50	4	8kN/Pair	2	9kN/Pair
BCPC80-100 / BCPC80SS-50	8	16kN/Pair	4	16kN/Pair

Note - for both fixing methods, all holes in bottom flange must be filled with ECKO 14g x 35mm Hex Head Screws. Loading is provided for uplift as per direction indicated.

Characteristic values have been derived from testing conducted by BRANZ (ST-18222) in accordance with EMI as specified in NZ3604:2011.

Commonly Used Scenarios

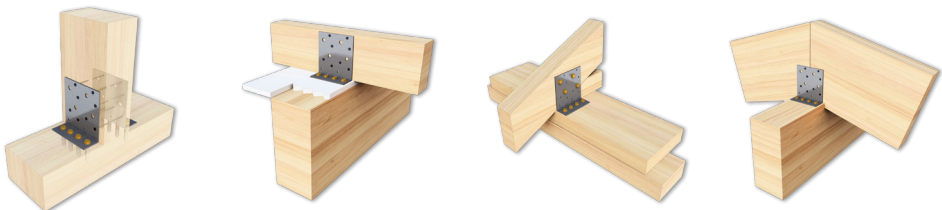

CPC Truss Fixings Guide

ECKO CPC's have been BRANZ tested and comply with NZS3604:2011 for fixing required for uplift of rafters, roof trusses, under purlins and ridge beams (for given loads). ECKO provide convenient truss fixing kits for both 9kN and 16kN, that include all required fixings.

9kN Truss Fixing Kit

Code	Kit / Bag	Bag / Outer
B9KNKIT	1	10

Each kit includes

- CPC40 x 2 units
- 14g x 35mm Zinc Hex Head Screws x 4 screws
- 14g x 75mm Zinc Hex Head Screws x 4 screws

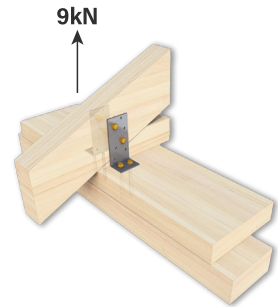
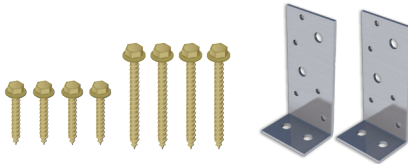

16kN Truss Fixing Kit

Code	Kit / Bag	Bag / Outer
B16KNKIT	1	10

Each kit includes

- CPC80 x 2 units
- 14g x 35mm Zinc Hex Head Screws x 8 screws
- 14g x 75mm Zinc Hex Head Screws x 8 screws

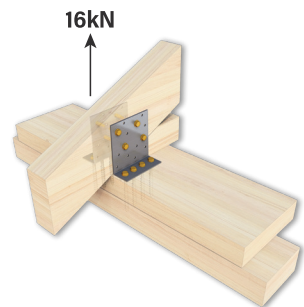
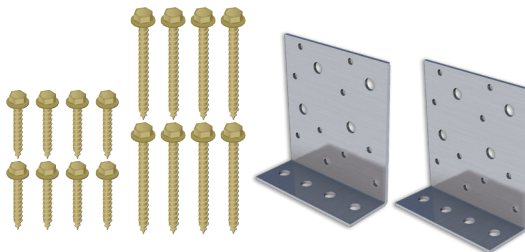

Steel Strap

Steel straps are a versatile fixing option widely specified in NZS3604:2011 for stud to bottom/top plate, lintel and rafter connections. As per NZS3604:2011 a 6kN capacity can be achieved with one strap (6/30 x 3.15mm nails each end) or 12kN with two straps (6/30 x 3.15mm nails each end).

Available in:

300, 400 & 600mm in lengths

Materials:

25 x 1.0mm G300 Z275 Galvanised Steel

25 x 1.0mm 304 Stainless Steel

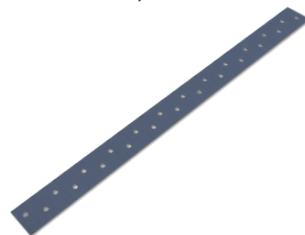

Steel Strap			
Code	Size (mm)	Finish	Pack QTY
BSBS300-100	300	Z275 Galvanised	100
BSBS400-100	400	Z275 Galvanised	100
BSBS600-100	600	Z275 Galvanised	100
BSBS300SS-100	300	304 S/Steel	100
BSBS400SS-100	400	304 S/Steel	100
BSBS600SS-100	600	304 S/Steel	100

Stud-to-Timber Floor Tie-Down

NOTE

6/30 x 3.15mm nails required in each end of strap to achieve required rating.

Stud-to-Bottom Plate Fixing

NOTE

Strap must be taken under bottom plate and 150mm up each side with 6/30 x 3.15mm nails required in each end of strap to achieve required rating.

Lintel Fixing

NOTE

6/30 x 3.15mm nails required in each end of strap to achieve required rating.

As per NZS3604:2011 clause 8.6.1.8 (figure 8.12)

MultiGrip - 130mm

ECKO MultiGrips are a versatile bracket that can be easily adjusted onsite to cover multiple fixing scenarios. Suitable for high load applications such as a tie-down connector for trusses or rafter to top-plates and for fixing joists to the face of bearers.

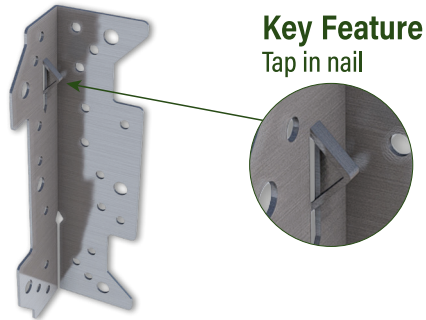

Materials:

- 1.0mm G300 Z275 Galvanised Steel
- 1.0mm 304 Stainless Steel

Load Table		Nails		Screws	
Shear		12kN / Pair		11kN / Pair	
Tension		3.2kN		-	
Code	Size (mm)	Finish		Pack QTY	
BMG130-25	130	Z275 Galvanised		25	
BMG130SS-25	130	304 S/Steel		25	

Characteristic Strengths have been derived from testing conducted by BRANZ (ST-18222) in accordance with EM1 as specified in NZ3604:2011.

Nails - 30 x 3.15mm

Screws - 14g x 35mm Hex Head

For use with nails all small holes must be filled and for screw fixing all large holes must be filled.

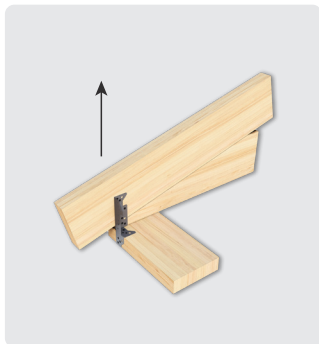

Tension

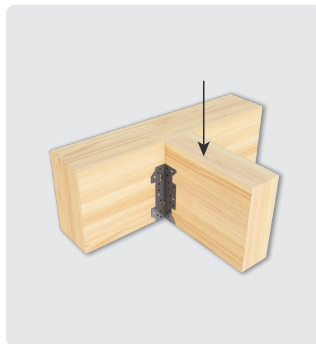

Shear

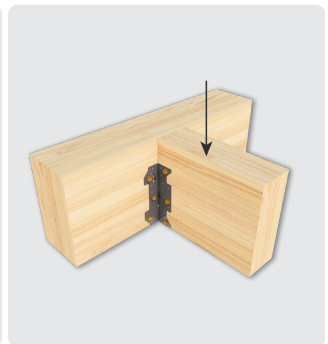

Shear

Stud Strap

Developed to secure studs to top plate in line with NZS3604. Pre-bent for ease of use, the stud strap can be applied to one face only, reducing the installation time relative to strap brace. Suitable for double 45mm top plates.

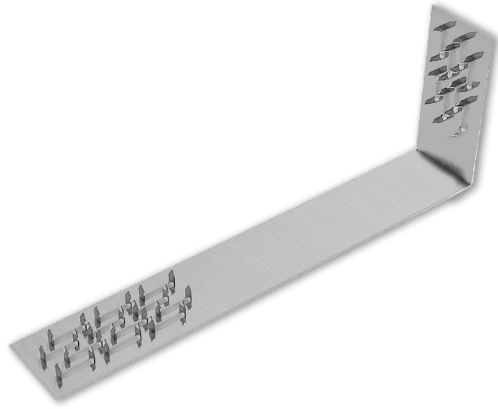

Materials:

1.0mm G300 Z275 Galvanised Steel

Stud Strap			
Code	Size (mm)	Finish	PCS / Pack
BSTUG-100	185	Z275 Galvanised	100

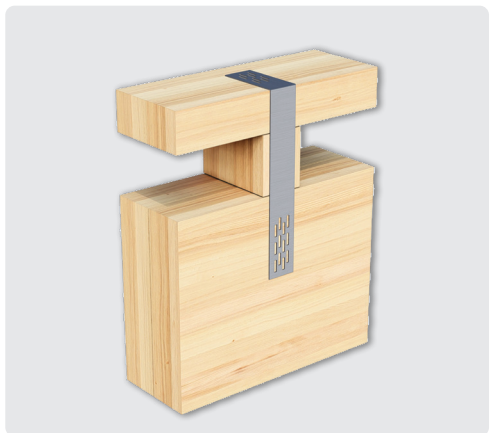

FrameFit Screw - Top Plate Fixing

ECKO's FrameFit Screw provides a fast, efficient and compliant solution for stud to top plate fixings.

- FrameFit screws have been tested to comply with Section 8 of NZS3604:2011 Type B Fixing 4.7kN.
- Faster installation than traditional wire dogs or strap fixings.
- Does not impact internal linings or rigid air barrier installation.
- Easily identified with provided tag for easy inspection.

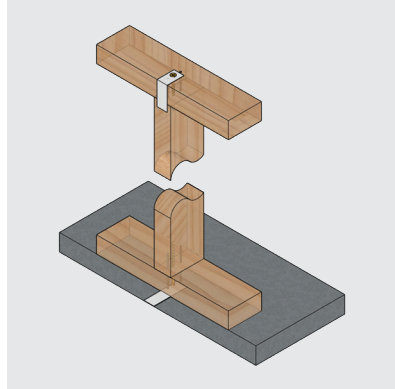
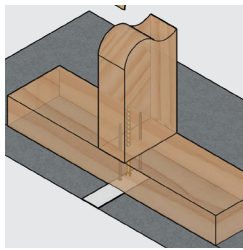
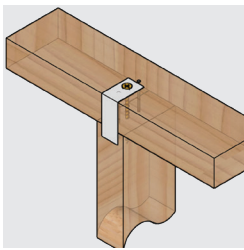

Can be installed in the factory, two sizes cover most top plate arrangements (single, double, capping)

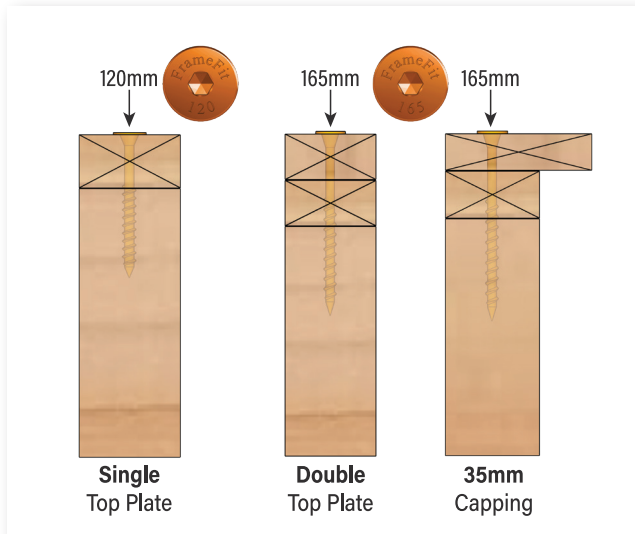

Split Hanger - 220mm

Designed to provide a strong 90° connection for larger timber widths and/or double joist/trusses to supporting members. The ECKO Split Hanger has been tested for use as a pair and where a single bracket is required, such as cantilevering beam to beam connections.



Materials:

1.6mm G300 Z275 Galvanised Steel

ECKO Split Hanger is made from 1.6mm G300 Z275 Galvanised (internal use) steel to ensure it meets all requirements set out in **NZS3604:2011** and **have been BRANZ Tested to ensure structural performance.**

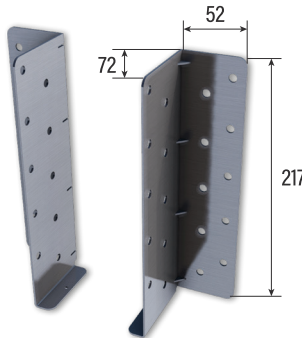

Characteristic Loads		Gravitational	Uplift
Split Hanger (Pair)		50kN	50kN
Single Bracket + 3 x M6 ECKO Construction Screws*		28kN	-
<p>Note - all holes filled with ECKO 14g x 35mm Hex Head Screws. *Minimum embedment of 60mm</p>			
Code	Size (mm)	Finish	PCS / Pack
BSH220-5PAIR	220	Z275 Galvanised	5

continued on next page →

Single Bracket

The ECKO Split Hanger has been BRANZ tested for gravitational loads when used as a single bracket, allowing it to be used as a corner cleat, where installing a second bracket is not feasible.



When installing a single split hanger additional end restraints are required. Use a minimum of 3 x M6 ECKO Construction screws or seek advice from project engineer. Screws should be aligned with centre of secondary beam and adhere to minimum edge from top/bottom of 50mm.

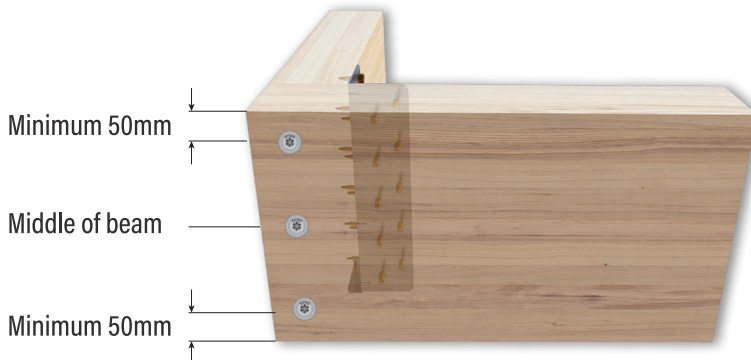

M6 ECKO Construction Screws with minimum embedment of 60mm in secondary beam
(ie 45mm timber = M6 x 120mm construction screw, 90mm timber = M6 x 180mm construction screw)

Panel Hold-Down Details

BRANZ TESTED - ST18221



Concrete Floor - Internal Wall

At both ends of the bracing element, the bottom plate is fixed using a ECKO's 15kN screw bolt. The bracket should be placed in the center of the bottom plate and all 5 screws be installed through the top flange into the corresponding stud.

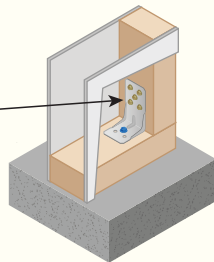

ECKO Bracing Bracket

Materials:
G300 Z275 Galvanised Steel

Concrete Floor - External Wall

At both ends of the bracing element, the bottom plate is fixed using a ECKO's 15kN screw bolt. The bracket should be aligned with the inside edge of the bottom plate to maximise edge distance. All 5 screws be installed through the top flange into the corresponding stud.

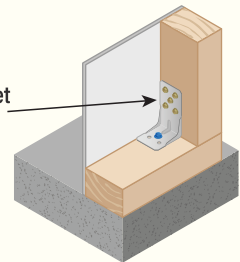

ECKO Bracing Bracket

Bracket Installation Guide

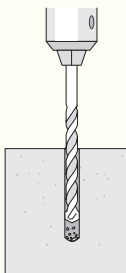

Step 1

Using the correct masonry drill bit, drill a hole to the required embedment +10mm. Ensure that the minimum edge distance of 55mm is adhered too.

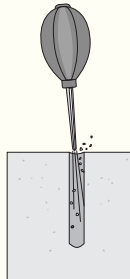

Step 2

Clean dust and debris from hole.

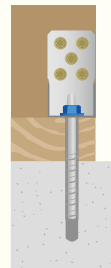

Step 3

Put the bracket in place and screw in anchor using torque wrench or impact wrench until flange head is firmly secured against the bracket. **DO NOT OVER-TIGHTEN. Install all 5 screws in top flange.**



Bracing Bracket Fixings Guide

ECKO Bracing Bracket has been developed and tested in NZ to be installed with commonly used bracing systems where hold-downs are required at both ends of the bracing element. The system was tested by BRANZ (ST-18221) under the EM1 methodology specified in NZS3604:2011.



KEY FEATURES

- Quick and easy to fit
- Provides a flush surface for internal lining
- Can be used as a substitute for bottom plate-to-stud hold-down straps
- Can be fitted at any stage before lining
- Easy for council inspection
- G300 Z275 Galvanised Steel

HotEdge

The ECKO M10 x 155 Screw Bolt (Orange Head) was developed in partnership with Firth to provide a fixing for a 90mm bottom plate where Firth's RibRaft HotEdge Extra insulation is used and can be substituted for the blue headed screw bolt provided. The Orange head screw bolt has been BRANZ tested (ST18050-01-02) and meets the required 15kN pullout rating to be used in common bracing systems, along with 3kN out of plane and 2kN in plane requirements set out in NZ3604:2011.

Bracket Installation with HotEdge Guide

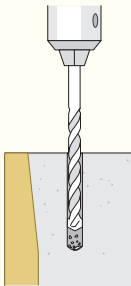

Step 1

Using a 10mm masonry drill bit, drill a hole to the required embedment + 10mm. Ensure that the minimum edge distance (from outside of insulation) of 58mm is adhered to.

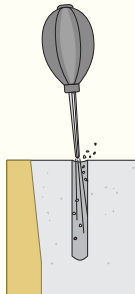

Step 2

Clean dust and debris from hole.

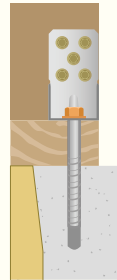

Step 3

Put the bracket in place and screw in anchor using torque wrench or impact wrench until flange head is firmly secured against the bracket. DO NOT OVERTIGHTEN. Install all 5 screws in top flange.

NOTE

* 15kN hold down is dependent on a minimum of 20MPa concrete.

** Two additional holes are provided on the bottom flange to allow specific engineered design for alternative fixings (ie balustrade fixing, post fire stability, etc)

12kN Pile Fixing Kit - Sea Spray Zone

ECKO 12kN Pile Fixing Kit is designed and tested to adhere to NZS3604:2011 requirements for braced and anchor pile fixing connections (pile-to-bearer and bearer-to-joist).

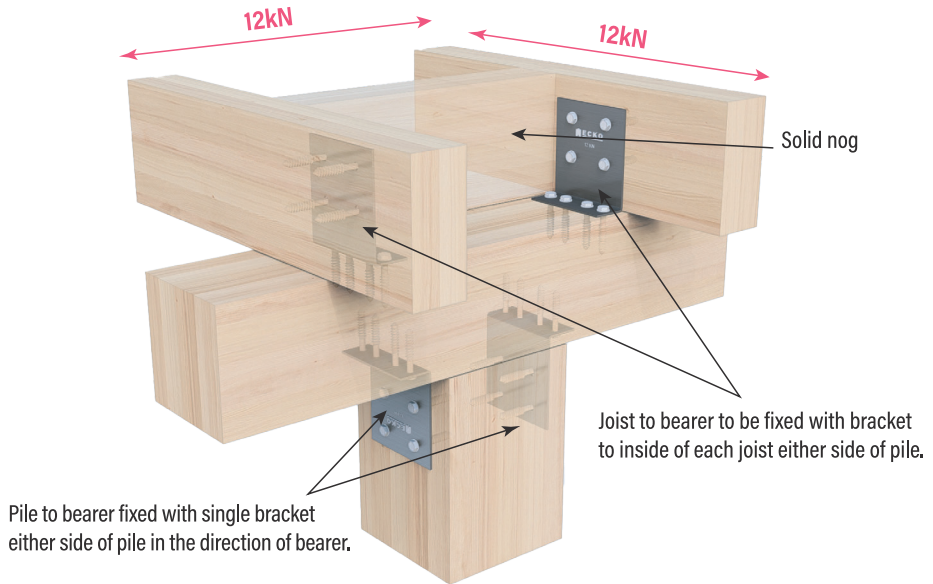

KEY FEATURES

- All screw fixed, ensuring easy and fast installation.
- No need to shave pile to fit bearer.
- All components are made from 304 S/Steel, suitable for high corrosion environments.

NOTE

- All construction must be in line with NZS3604:2011 and fixings set out in this document
- Solid blocking is required directly over braced or anchor pile
- Lateral support to floor joists must be within 300mm of bearer or bracing lines (NZS3604)
- Round piles must be checked out to ensure bracket sits flush with pile
- Joists must be a minimum of 140mm
- Where possible bearer to be centrally located on pile
- Minimum pile size: 125 x 125mm square, 140mm round
- All bracket holes to be filled

12kN Pile Fixing

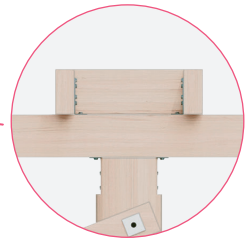
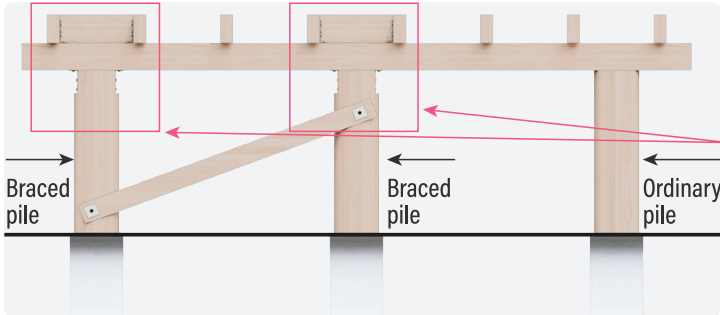

Braced & Anchor Pile
as per NZS3604:2011

12kN Pile Fixing

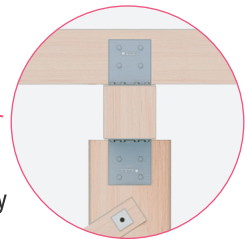
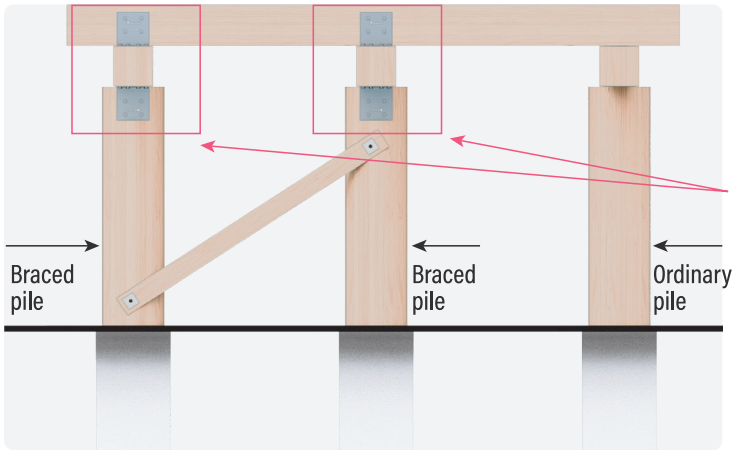

Braced & Anchor Pile
as per NZS3604:2011



12kN Pile Fixing Kit

Code	Kit / Bag	Bag / Outer
BSSPILE12KN	1	10
Each kit includes <ul style="list-style-type: none"> 12kN 304 S/Steel Pile Fixing Brackets x 4 units 14g x 45mm 304 S/Steel Hex Head Screws x 32 screws 		



6kN Pile Fixing Kit - Sea Spray Zone

ECKO 6kN Pile Fixing Kit is designed and tested to adhere to NZS3604:2011 requirements for cantilever pile fixing connections (pile-to-bearer and bearer-to-joist).

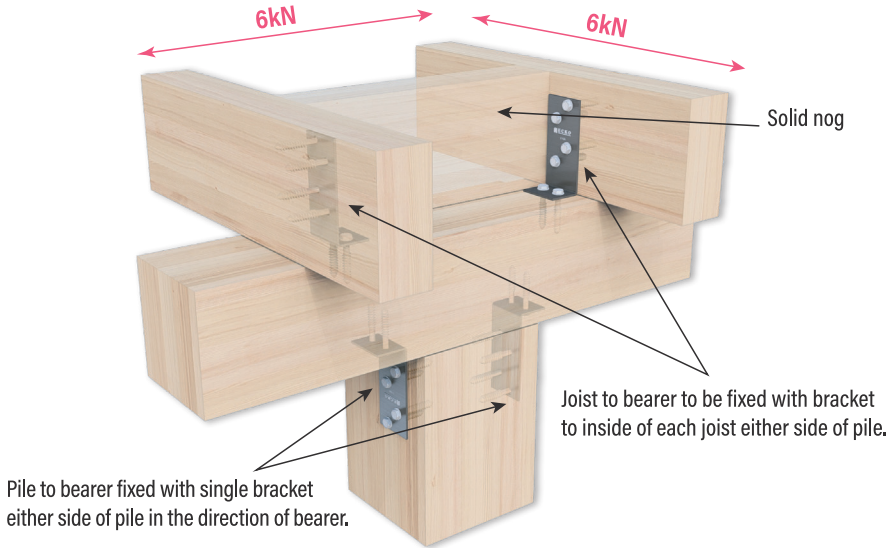

KEY FEATURES

- All screw fixed, ensuring easy and fast installation.
- No need to shave pile to fit bearer.
- All components are made from 304 S/Steel, suitable for high corrosion environments.

NOTE

- All construction must be in line with NZS3604:2011 and fixings set out in this document.
- Solid blocking is required directly over cantilever pile.
- Lateral support to floor joists must be within 300mm of bearer or bracing lines (NZS3604).
- Round piles must be checked out to ensure bracket sits flush with pile.
- Joists must be a minimum of 140mm
- Where possible bearer to be centrally located on pile
- Minimum pile size: 125 x 125mm square, 140mm round
- All bracket holes to be filled.

6kN Pile Fixing

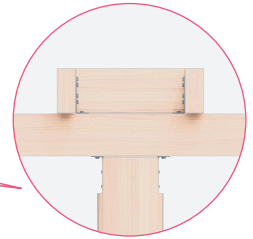
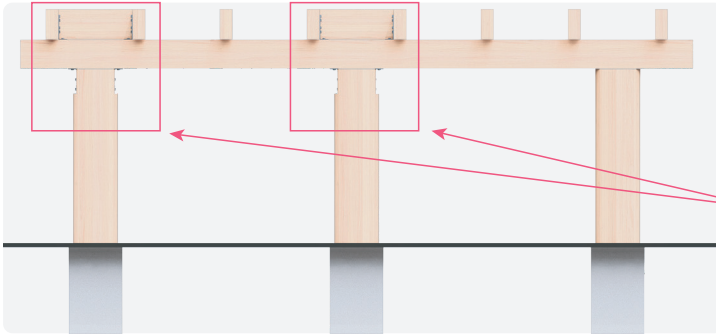

Cantilever Pile
as per NZS3604:2011

6kN Pile Fixing

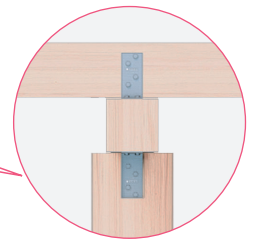
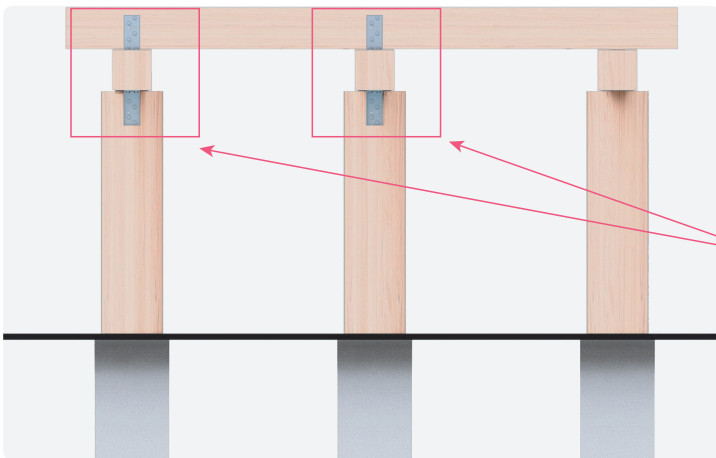

Cantilever Pile
as per NZS3604:2011



6kN Pile Fixing Kit

Code	Kit / Bag	Bag / Outer
BSSPILE6KN	1	10
Each kit includes <ul style="list-style-type: none"> ▪ 6kN 304 S/Steel Pile Fixing Brackets x 4 units ▪ 14g x 45mm 304 S/Steel Hex Head Screws x 24 screws 		

