



makes your job easier

TECHNICAL DATA

TEST REPORTS

T-REX17® Batten Screws Pull Out Test

Bugle head, Hex drive - OutDoor XGuard

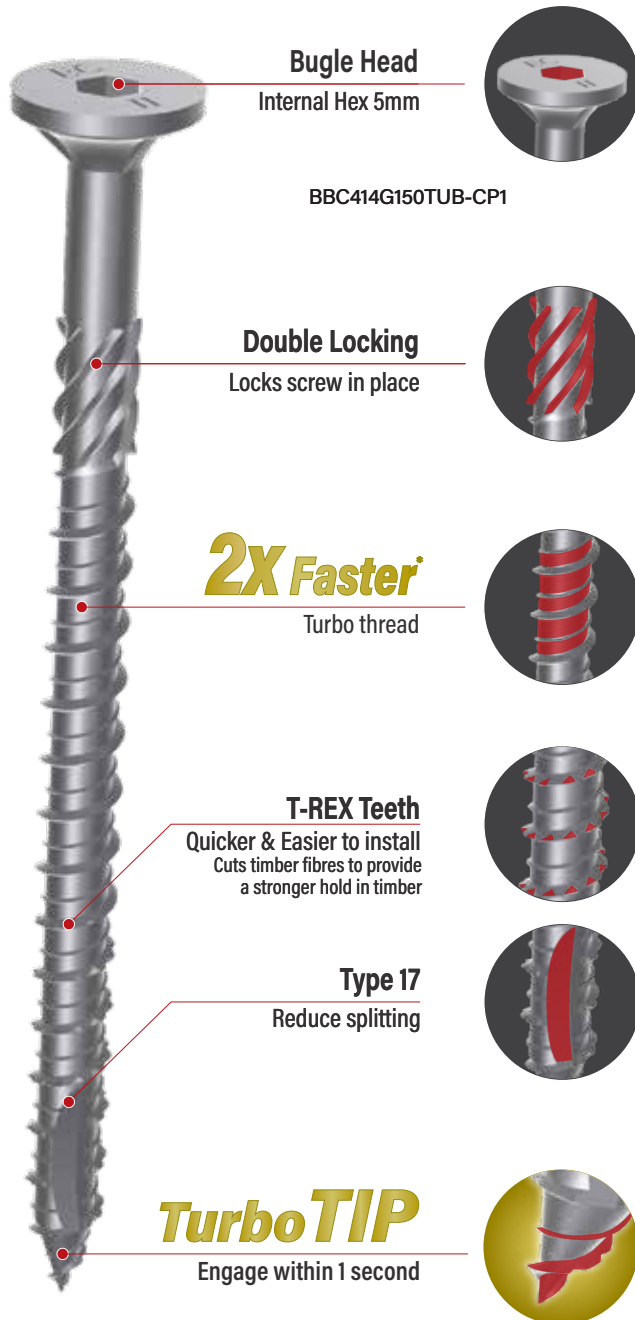

COMPLIES WITH NZS3604:2011













The ECKO 14G x 100mm Batten Screw is the ideal fastener for fixing purlins to rafters or trusses, and complies with NZS3604:2011 requirements.

OutDoor XGuard Salt Spray Test



The 14G x 100mm Batten Screw with an Internal Hex Drive features T-Rex Teeth technology for a quicker, easier installation, while its bugle head ensures a clean, flush finish with maximum holding power.

Observations & Result

Specimens displaying red rust of fasteners shaft [%] & examination period [hours]

| Observations & Results | | | |
|-------------------------------------------------------------------------------------|-------------------------------------------------------------------------------------|--------------------------------------------------------------------------------------|---------------------------------------------------------------------------------------|
| Other brand Class 3 coating | | | |
|  |  |  |  |
| 0% - 120 hours | 50% - 240 hours | 67% - 500 hours | 100% - 1000 hours |
| Other brand Class 4 Galvanised | | | |
|  |  |  |  |
| 0% - 120 hours | 0% - 240 hours | 17% - 500 hours | 100% - 1000 hours |
| ECKO T-REX17® 14G batten screw OutDoor XGuard premium coating | | | |
|  |  |  |  |
| 0% - 120 hours | 0% - 240 hours | 0% - 500 hours | 0% - 1000 hours |

OutDoor XGuard has gone through numerous salt-spray testing in line with ATSM-B117-Standard Practice for Operating Salt Spray (Fog) Apparatus as specified in ISO12944. Based on 1500 hours, OutDoor XGuard achieves C4 - Corrosivity: High (industrial areas or coastal with moderate salinity) and Durability: High greater than 15 years.

| Environment | Durability |
|-----------------------------------------------------------------------------------------------------------------------------------------------------------------|--------------------------------------------------------------------------------------------------------------------------------------------------------------------------------------------------------------------------|
| High Corrosivity - Industrial areas or coastal areas with moderate salinity | Greater than 15 years. |
|  <p>Observations & Result of OutDoor XGuard & Class 4 Galvanised</p> |   <p>OutDoor XGuard Class 4 Galvanised</p> |

** There is no absolute relationship between Salt-Spray chamber and real-life, however it is generally accepted to be the most measure of corrosion rates outside of real world testing.

T-REX17® 316 Stainless Steel 8g JoltScrew Pull Out Test

For weatherboard applications



SUMMARY OF TESTING AND ENGINEERING DESIGN

Potius Building Systems has been engaged by ECKO Fastening Systems to assess the withdrawal capacity of their T-REX17® 8G JoltScrew 316 Stainless Steel for weatherboard applications. A series of pullout tests were performed with SG8 H1.2 framing (Radiata Pine) and 19mm H3 primed weatherboards (Radiata Pine) in accordance with AS1649 and NZS3603. With 30mm embedment of the screws into framing the following characteristic withdrawal values were obtained:

| Holding Power | | |
|---------------------------------------------------------|------------------------------------------------|---------------------------------------------------------|
| JoltScrew has 6x more holding power than Jolt Head Nail | | |
| Fixing Type | Withdraw in pine - 31mm penetration (LPL - kN) | Head pull through in weatherboard 19mm thick (LPL - kN) |
| JoltScrew 316 S/Steel 8g x 75mm | 3.89 | 1.48 |
| JoltScrew 316 S/Steel 8g x 90mm | 5.29 | 1.48 |
| Jolt Head Nail 75 x 3.15mm | 0.66 | 0.56 |
| Jolt Head Nail 60 x 2.80mm | 0.54 | 0.32 |

LPL Lower Proportional Limit as per NZS3603

NOTE The Jolt head nails were bright steel used in testing. Testing with Galvanised Jolt head nails may result in slightly higher pullout values.

The compliance path for non - structural claddings is by meeting the requirements of NZBC E2 External Moisture. This statement addresses the structural fixing capacity rating of the T-REX17® 8G JoltScrew at 600mm c/c structural supports by testing and structural calculation. Engineering calculation based on a ULS wind pressure of 2.5kPa (E2/VM1 clause 1.3) has been performed to ensure the T-REX17® 8G JoltScrew have sufficient holding power fastened at 600mm c/c both for the weatherboard to battens and withdrawal from the framing timber also at 600mm c/c. For vertically direct-fixed weatherboards E2/AS1 states that dwangs must be at 480mm centers maximum (clause 9.1.8.5 & Table 24), however we have calculated that dwangs or Structural Battens at 600mm c/c also work with the holding force of the T-REX17® 8G JoltScrew. Where vertical cladding is fastened through the cladding into the Structural Framing or Structural Cavity Battens, 30mm penetration minimum into the structural framing or structural batten is required, refer to details 1-3 for the structural fixing details below.



DIRECT FIXED

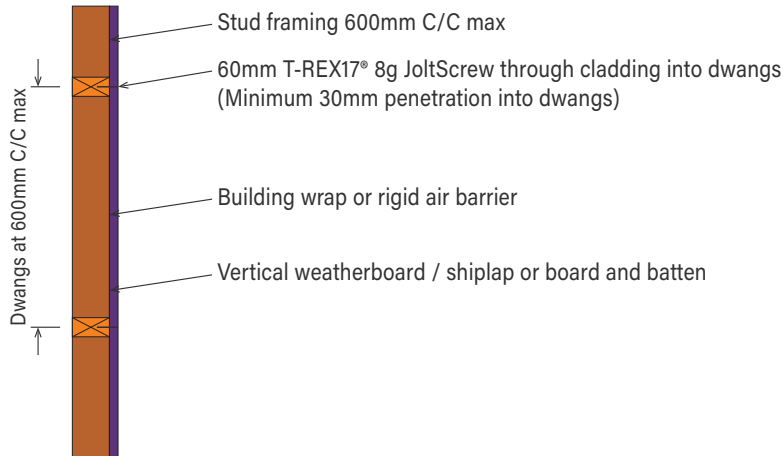

OVER 20mm CAVITY BATTENS

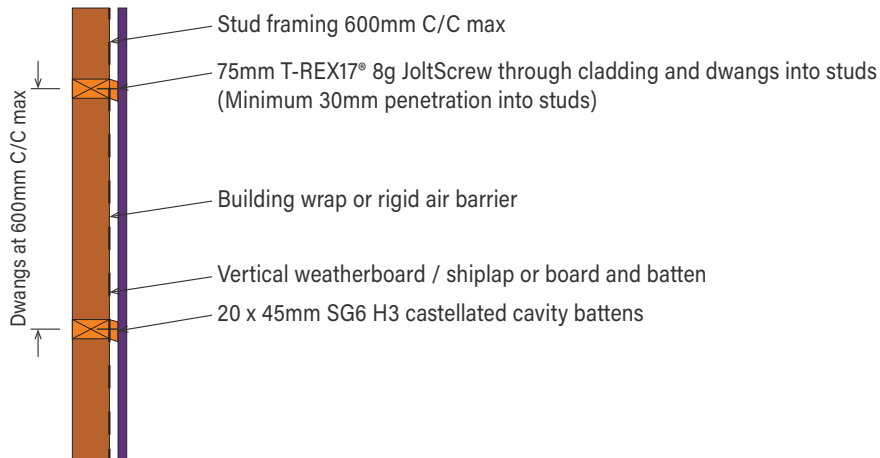

OVER 45mm CAVITY BATTENS

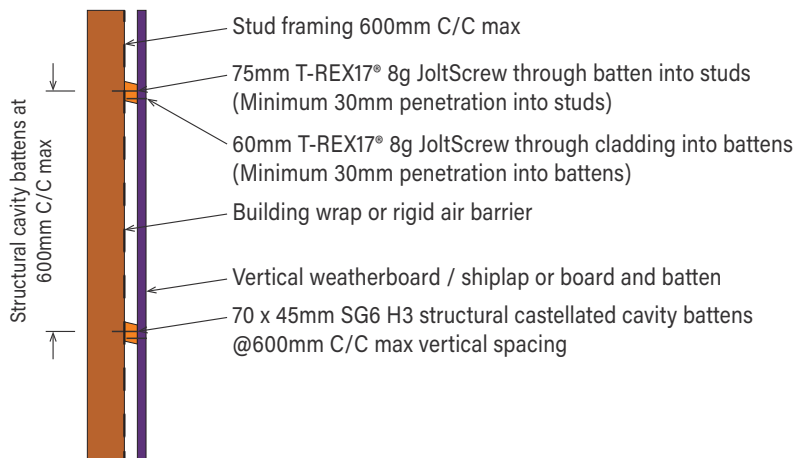

I believe on reasonable grounds that using T-REX17® 8G JoltScrew installed according to the details shown above will meet the requirements of E2 and be able to:

1. Resist the wind pressure causing suction of the weatherboard.
2. Resist movement between the framing and weatherboard that might loosen the fixing.

Regards,

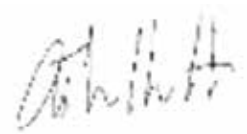

Andy Van Houtte

CMengNZ, CPEng, IntPE

REFERENCED STANDARDS:

MBIE E2/AS1/VM1: External Moisture.

AS1649 Timber. Methods of tests for mechanical fasteners and connectors.

AS/NZS1170.0 B1 Use of test data for design.

NZS3603: Engineered Timber.

NZS3604: Timber Framed Buildings.

NZS3617 Profiles of Weatherboards, Fascia Boards and Flooring.

BRANZ BU411 – Recommended Timber Cladding Profiles.

BRANZ BU582 – Structurally Fixed Cavity Battens.



Characteristic Capacities for the design of structural connections with ECKO T-REX17® Construction Screws

ECKO T - REX17® construction screws are partially threaded, which work by clamping two timber members together. They come in two head types, Wafer head, to provide a high clamping force and Countersunk which is used for flush fixings. ECKO T - REX17® construction screws are coated with OutDoor XGuard Galvanising for use in outdoor conditions as per NZS3604 corrosion zone Table 4.3 Nail and Screw use.

Construction Screw - Wafer Head

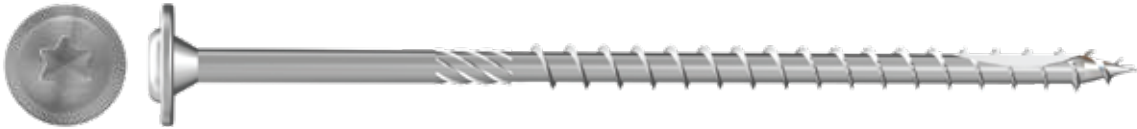

Construction Screw - Countersunk Head



| ECKO T-REX17® Construction Screws Range | | | | | |
|-----------------------------------------|------------------------|---------|------------------|---------|---------|
| | Countersunk Head (TCC) | | Wafer Head (TCW) | | |
| | M8 | M10 | M6 | M8 | M10 |
| Thread diameter | 8mm | 10mm | 6mm | 8mm | 10mm |
| Head diameter | 14.9 | 18.7 | 15.3 | 21 | 24.7 |
| Bit driver | T-40 | T-50 | T-30 | T-40 | T-50 |
| Point | Type 17 | Type 17 | Type 17 | Type 17 | Type 17 |
| Screw length (mm) | lgT | lgT | lgT | lgT | lgT |
| 80 | 50 | 50 | 50 | 50 | 50 |
| 100 | 60 | 60 | 60 | 60 | 60 |
| 120 | 60 | 60 | 60 | 60 | 60 |
| 140 | 80 | 80 | 80 | 80 | 80 |
| 160 | 80 | 80 | 80 | 80 | 80 |
| 180 | 80 | 80 | 80 | 80 | 80 |
| 200 | 80 | 80 | 80 | 80 | 80 |
| 220 | 80 | 80 | 80 | 80 | 80 |
| 240 | 80 | 80 | 80 | 80 | 80 |
| 260 | 80 | 80 | 80 | 80 | 80 |
| 280 | 80 | 80 | 80 | 80 | 80 |
| 300 | 80 | 80 | 80 | 80 | 80 |
| 320 | 80 | 80 | | 80 | 80 |
| 340 | 80 | 80 | | 80 | 80 |
| 360 | 80 | 80 | | 80 | 80 |
| 400 | 80 | 80 | | 80 | 80 |

CONNECTION DESIGN USING ECKO T - REX17® SCREWS

Introduction

This guide has been developed from testing according to AS1649 – Methods of test for mechanical fasteners and connectors and EN1382/3 Timber structures test methods, to determine limit state design parameters. It is intended for use in conjunction by a design professional, for engineering designs in accordance with NZS3603 – Timber Structures, AS1720.1 – Timber Structures, NZS AS1720.1 – Timber Structures and Eurocode 5 - Timber.

Description of Testing

Sets of screw tests were performed in a matrix of withdrawal and lateral shear orientations to provide design data on SG8 (also GL8) Radiata Pine and LVL11 (face and edge) Radiata Pine timber material types. Temperature, humidity, moisture content and densities were recorded to ensure the material was within test parameters. Tests were performed without predrilling holes.

| ECKO T-REX17® Construction Screws Mechanical Properties | | | | | | | |
|-----------------------------------------------------------------------------------|--------------|----------------------|------------------------|------|------------------|------|------|
| Head Type | | | Countersunk Head (TCC) | | Wafer Head (TCW) | | |
| Nominal Diameter | D1 | (mm) | 8 | 10 | 6 | 8 | 10 |
| Head Diameter | dk | (mm) | 14.9 | 18.7 | 15.3 | 21.0 | 24.7 |
| Thread Diameter | d1 | (mm) | 8.0 | 10.0 | 6.0 | 8.0 | 10.0 |
| Shank Diameter | ds | (mm) | 5.8 | 7.0 | 4.2 | 5.8 | 7.0 |
| Yield Moment | $M_{y,k}$ | (Nm) | 20.4 | 34.5 | 7.6 | 20.4 | 34.5 |
| Tensile Capacity | $f_{tens,k}$ | (kN) | 27.8 | 37.6 | 12.9 | 27.8 | 37.6 |
| Characteristic Withdrawal Parameter (Associated density - 480kg/m3 LVL) | $f_{ax,k}$ | (N/mm ²) | 17.2 | 17.2 | 17.2 | 17.2 | 17.2 |
| Characteristic Withdrawal Parameter (Associated density - 375kg/m3 SG8) | $f_{ax,k}$ | (N/mm ²) | 14.1 | 14.1 | 14.1 | 14.1 | 14.1 |
| Characteristic Head Pull Through Parameter (Associated density - 480kg/m3 LVL) | $f_{head,k}$ | (N/mm ²) | 14.6 | 14.6 | 14.6 | 14.6 | 14.6 |
| Characteristic Head Pull Through Parameter (Associated density - 375kg/m3 SG8) | $f_{head,k}$ | (N/mm ²) | 10.7 | 10.7 | 10.7 | 10.7 | 10.7 |

Construction Screw - Wafer Head

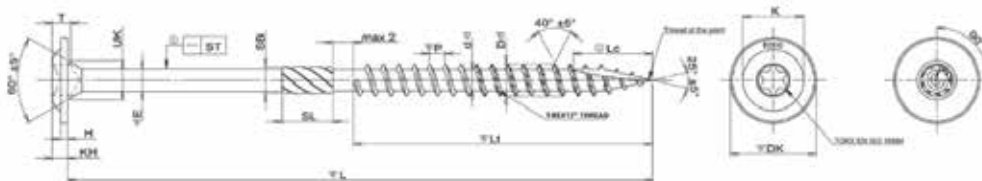

Construction Screw - Countersunk Head

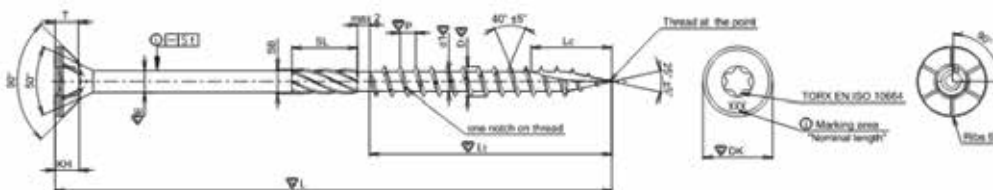

CHARACTERISTIC CAPACITY FOR A ECKO T-REX17® SINGLE SCREW IN SIDE GRAIN LOADED IN SINGLE SHEAR

| SG8 (Radiata Pine) | Fixing Type | Shank Diameter (mm) | Characteristic Capacity of a single screw in side grain laterally loaded in single shear (N) |
|-----------------------|---------------|---------------------|----------------------------------------------------------------------------------------------|
| | M8 x 140 TCC | 5.8 | 1940 |
| | M10 x 140 TCC | 7.0 | 2890 |
| | M6 x 140 TCW | 4.2 | 1260 |
| | M8 x 140 TCW | 5.8 | 1940 |
| | M10 x 140 TCW | 7.0 | 2890 |

| LVL11 Face ³ (Radiata Pine) | Fixing Type | Shank Diameter (mm) | Characteristic Capacity of a single screw in side grain laterally loaded in single shear (N) ^{1,2} |
|-------------------------------------------|---------------|---------------------|-------------------------------------------------------------------------------------------------------------|
| | M8 x 140 TCC | 5.8 | 3430 |
| | M10 x 140 TCC | 7.0 | 3870 |
| | M6 x 140 TCW | 4.2 | 1440 |
| | M8 x 140 TCW | 5.8 | 3430 |
| | M10 x 140 TCW | 7.0 | 3870 |

1. Based on tests performed in double shear using 3/45mm dry timber members. Results are calculated for single shear.
2. The lateral loads for screws in side grain is assumed to be the same for load direction parallel and perpendicular to grain (verified by testing).
3. For LVL8 and LVL11 Edge orientation assume SG8 values. For LVL13 use LVL11 values.

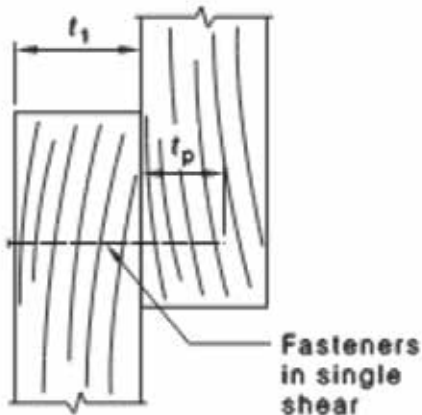

(a) Two-member Type 1 joint

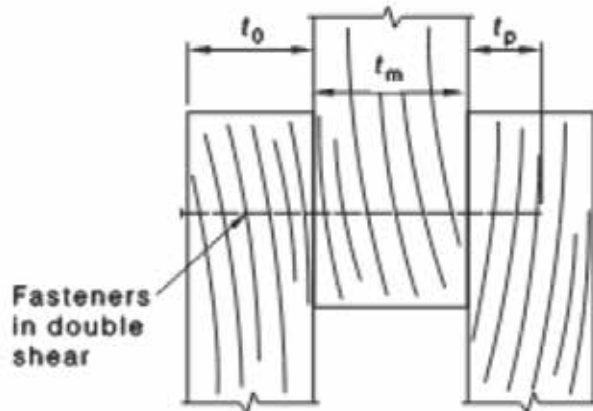

(b) Three-member Type 1 joint

CHARACTERISTIC CAPACITY FOR A ECKO T-REX17® SINGLE SCREW IN SIDE GRAIN LOADED IN WITHDRAWAL

| SG8 (Radiata Pine) | Fixing Type | Withdrawal (kN) 80mm thread penetration | Characteristic Withdrawal (N/mm) | Head Pull Through (kN) |
|-----------------------|---------------|--------------------------------------------|-------------------------------------|---------------------------|
| | M8 x 140 TCC | 8.0 | 102 | 3.3 |
| | M10 x 140 TCC | 9.1 | 114 | 4.3 |
| | M6 x 140 TCW | 6.5 | 81 | 2.9 |
| | M8 x 140 TCW | 8.0 | 102 | 4.6 |
| | M10 x 140 TCW | 9.1 | 114 | 8.0 |

| LVL11 Face ³ (Radiata Pine) | Fixing Type | Withdrawal (kN) 80mm thread penetration | Characteristic Withdrawal (N/mm) | Head Pull Through (kN) |
|-------------------------------------------|---------------|--------------------------------------------|-------------------------------------|---------------------------|
| | M8 x 140 TCC | 9.1 | 114 | 4.0 |
| | M10 x 140 TCC | 10.6 | 133 | 5.3 |
| | M6 x 140 TCW | 7.1 | 89 | 3.7 |
| | M8 x 140 TCW | 9.1 | 114 | 6.7 |
| | M10 x 140 TCW | 10.6 | 133 | 7.8 |

| LVL11 Edge (Radiata Pine) | Fixing Type | Withdrawal (kN) 80mm thread penetration | Characteristic Withdrawal (N/mm) | Head Pull Through (kN) |
|------------------------------|---------------|--------------------------------------------|-------------------------------------|---------------------------|
| | M8 x 140 TCC | 8.0 | 100 | 3.7 |
| | M10 x 140 TCC | 10.3 | 129 | 5.7 |
| | M6 x 140 TCW | 6.6 | 83 | 3.4 |
| | M8 x 140 TCW | 8.0 | 100 | 5.7 |
| | M10 x 140 TCW | 10.3 | 129 | 8.7 |

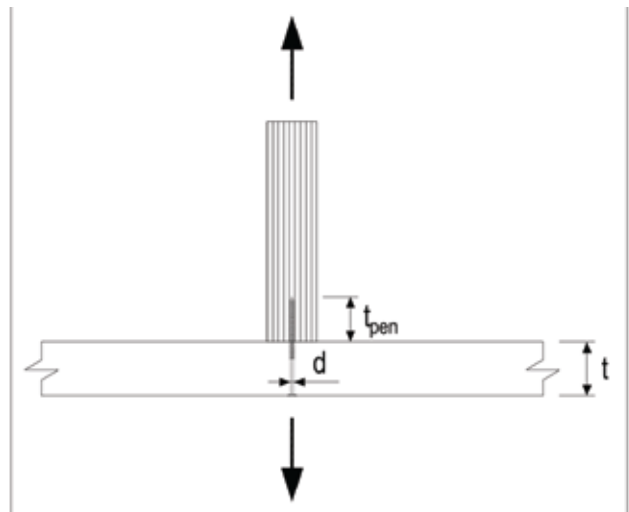
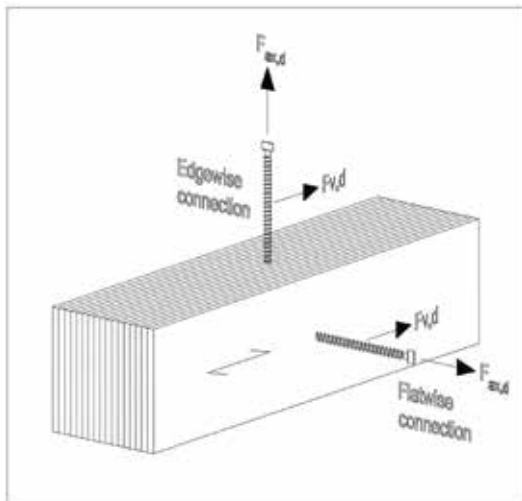

Figure 5.2.

Edgewise (edge face) and flatwise (wide face) orientations and loading types of connections. $F_{ax,d}$ are forces of axially loaded and $F_{vx,d}$ are forces of laterally loaded connections ³⁴.

Minimum Recommended Spacing of Screws (mm) ¹

| | | M6 | M8 | M10 |
|------------------------|-------|----|-----|------|
| Thread diameter, d1 | | 6 | 8 | 10 |
| Spacing along grain | a1 | 60 | 80 | 100 |
| Spacing across grain | a2 | 30 | 40 | 50 |
| Loaded end distance | a3, t | 90 | 120 | 150 |
| Unloaded end distance | a3, c | 50 | 60 | 80 |
| Loaded edge distance | a4, t | 30 | 40 | 45 |
| Unloaded edge distance | a4, c | 15 | 20 | 22.5 |

1. Without predrilled holes. For LVL edge orientation, increase spacing along, a1, by 20mm.

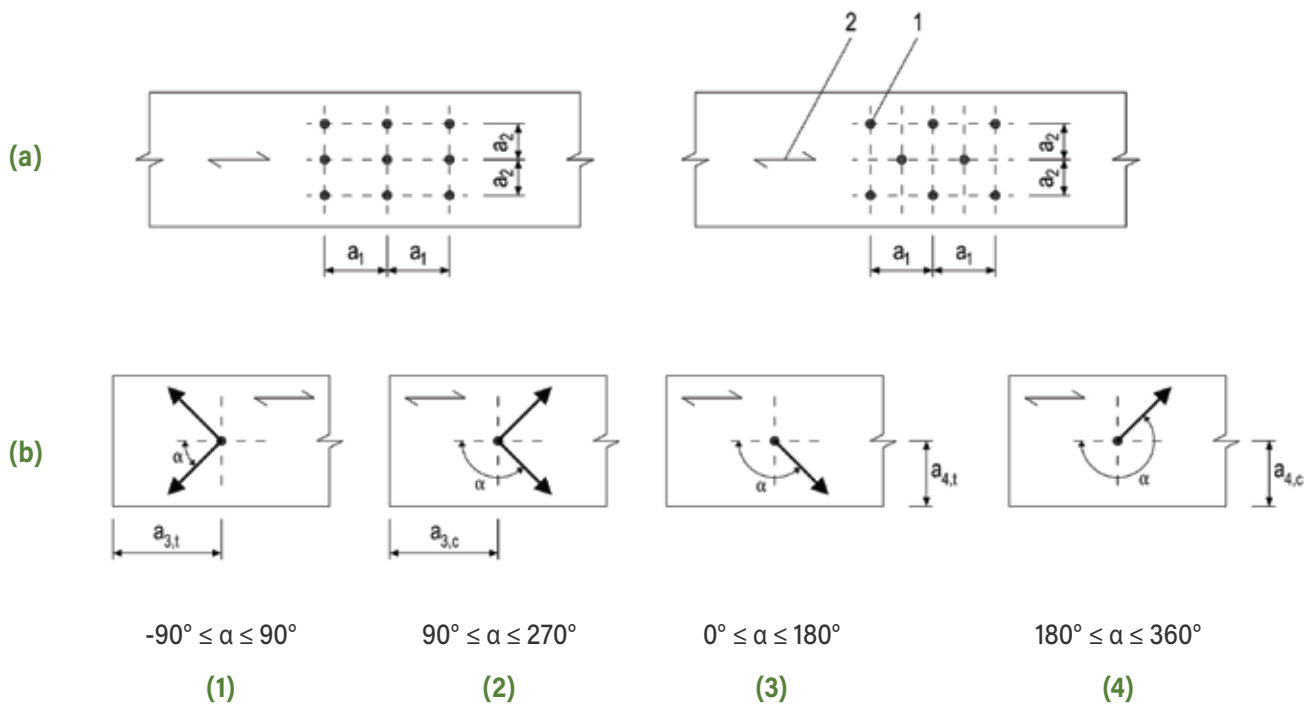

Key:

- (1) Loaded end
- (2) Unloaded end
- (3) Loaded edge
- (4) Unloaded edge
- 1 Fastener
- 2 Grain direction

PRODUCT STATEMENT

ECKO T-REX17® Construction Screws.

Potius Building Systems Ltd has been engaged by Ecko Fastening Systems to test and develop design parameters for the Ecko T-REX17® M6, M8 & M10 range of screws. Testing has been generally carried out in accordance with AS1684 and EN1382/83 and adapted where necessary to provide useable results. We believe on reasonable grounds that the characteristic values contained in this Design Guide will meet the requirements of clauses B1/VM1 of the New Zealand Building Code documents.

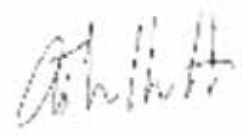

Andy Van Houtte

CMengNZ, CPEng

For Potius Building Systems Ltd

December 2022 (validity of producer statement 2 years from this date)

REFERENCED STANDARDS:

AS1649 – Methods of test for mechanical fasteners and connectors

AS1720.1 – Timber Structures

BRANZ EM1 Structural Joint Strength and Stiffness Evaluation

NZS3603 – Timber Structures

NZS AS1720.1 – Timber Structures

EN 1382 – Withdrawal Capacity of Timber Fasteners

EN 1383 – Fastener Head Pull Through

EN 14358 – Calculation and Verification of Characteristic Values



ECKO T-REX17® Purlin Screws Fixing Guide

ECKO T - REX17® Purlin Screw, 10g x 80mm, Countersunk Head, T25 Drive, Blue Ruspert

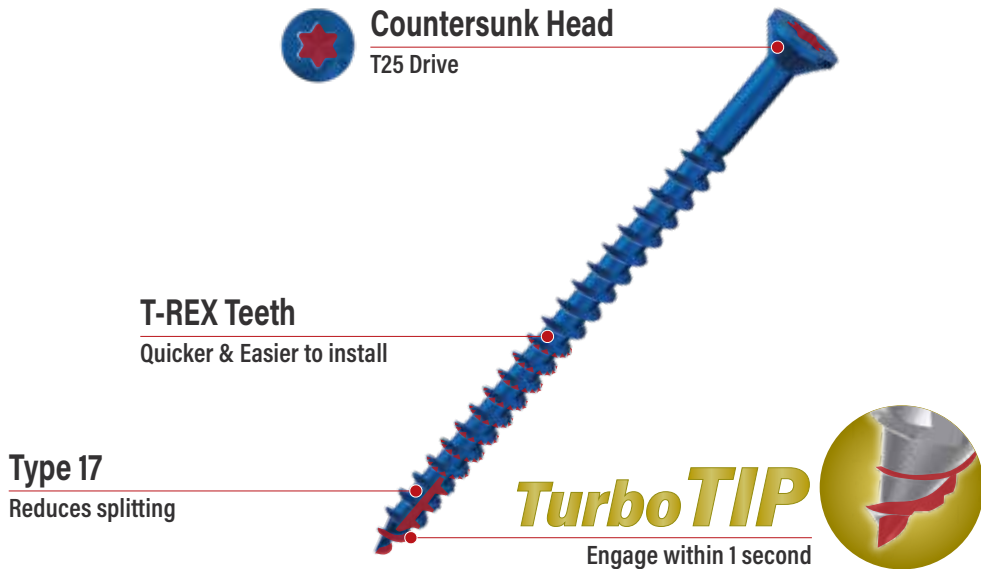

Purlin / Batten

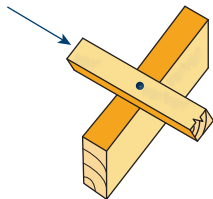

1 / ECKO T-REX17® Purlin Screw,
10g x 80mm

4.79kN
Characteristic Strength

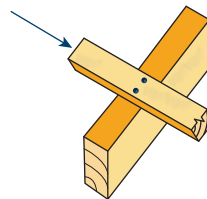

2 / ECKO T-REX17® Purlin Screw,
10g x 80mm (for purlin on edge)

9.19kN
Characteristic Strength

Fixing Guide (Maximum Spacing & fixing)

This is a guide ONLY, reference Table 10.10, section 10 of NZS 3604:2011

| Purlin Size | Max. SPAN | Low | | Medium | | High | | Very High | | Extra High | |
|-------------|-----------|---------|--------|---------|--------|---------|--------|-----------|--------|------------|--------|
| | | Spacing | Fixing | Spacing | Fixing | Spacing | Fixing | Spacing | Fixing | Spacing | Fixing |
| 70 x 45 | 900mm | 900mm | S | 900mm | T | 900mm | T | 900mm | T | 900mm | U |
| 70 x 45 | 900mm | 1200mm | T | 1200mm | T | 1200mm | T | 1050mm | U | 900mm | U |
| 70 x 45 | 900mm | 1800mm | T | 1800mm | U | 1400mm | U | 1050mm | U | 900mm | U |
| 70 x 45 | 1200mm | 1200mm | T | 1150mm | T | 800mm | T | 600mm | T | 500mm | T |
| 70 x 45 | 1200mm | 1300mm | T | 1150mm | T | 800mm | T | 600mm | T | 500mm | T |
| 90 x 45 | 1200mm | 1700mm | T | 1450mm | U | 1000mm | U | 750mm | U | 650mm | U |

| Fixing Type | Description | Alternative Fixing Capacity (kN) |
|-------------|------------------------------------------------------------------------------------------|----------------------------------|
| S | 2 x 90 x 3.15mm framing nails | 0.8 |
| T | 1 x 10g x 80mm ECKO T-REX17® Purlin Screws | 2.4 |
| U | 2 x 10g x 80mm ECKO T-REX17® Purlin Screws or 1 x 14g x 100mm ECKO T-REX17® Batten Screw | 5.5 |

NOTE All fixing types are determined as required for the higher uplift loads at the periphery of the roof (based on local pressure factors in AS/NZS1170.2)
*Please refer to the technical specification for fastener requirements or installation manual for each specific application you are working with.

15kN Bottom Plate Fixing Guide

Mechanical Galvanised

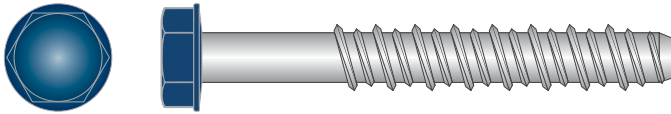

ECKO 15kN Bottom Plate Fixing

| Dia. | Length (mm) | Product Code | Application | PCS / Tub |
|----------|-------------|------------------|------------------------------------------|-----------|
| M10/15kN | 140 | SBGXM10140TUB-50 | 15kN bottom plate fixing | 50 |
| | 150 | SBGXM10150TUB-50 | 15kN bottom plate fixing (frames packer) | |

Includes 50pcs x washer, 1pc x socket driver bit, 1pc x drill bit.

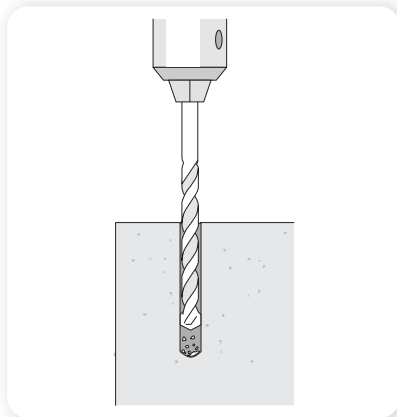

Step 1
Using the correct masonry drill bit, drill a hole to the required embedment +10mm. Ensure that the minimum edge distance of 55mm is adhered to.

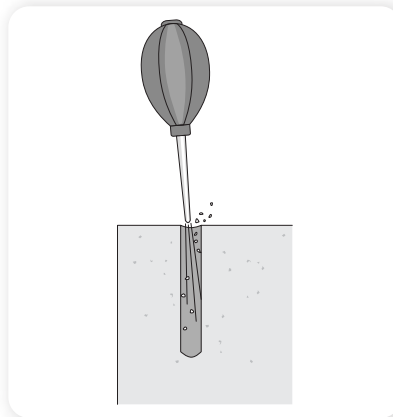

Step 2
Clean dust and debris from hole.

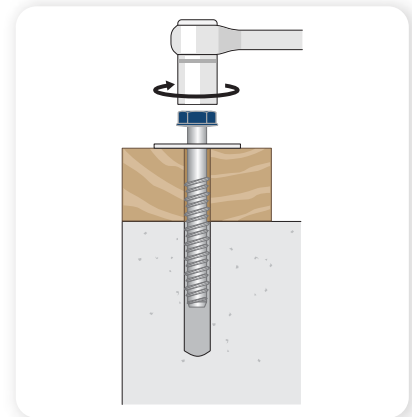

Step 3
Screw in anchor using torque wrench or impact wrench until flange head is firmly secured against washer. **DO NOT OVER-TIGHTEN.**

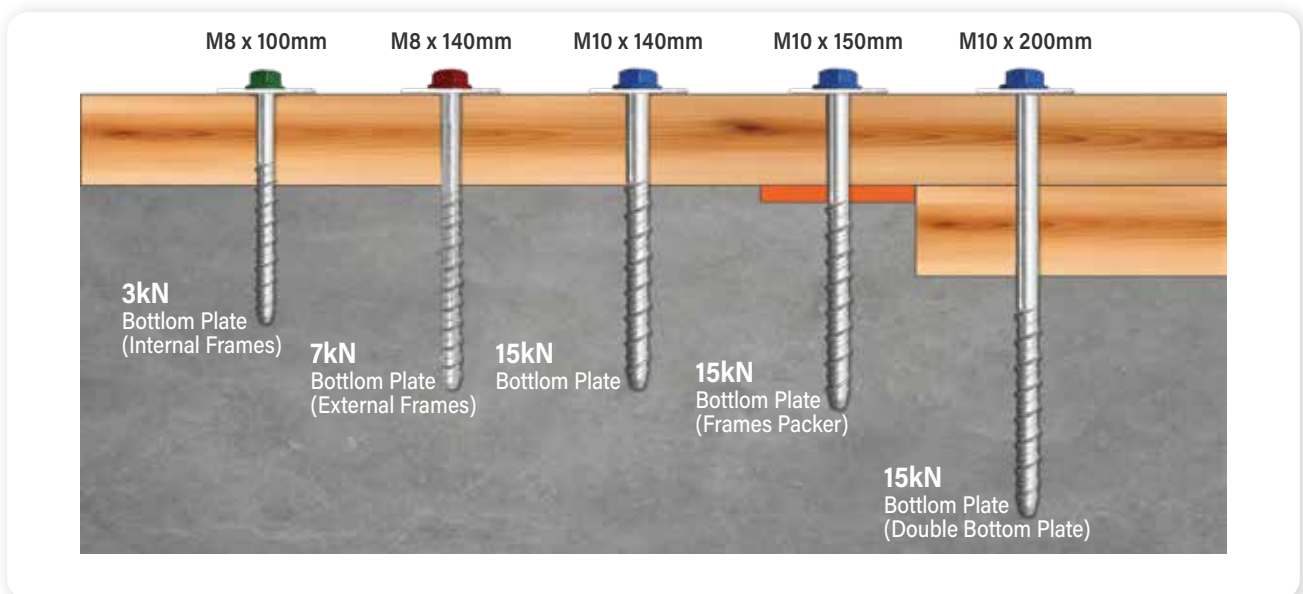

15kN Bottom Plate Fixing Guide

Mechanical Galvanised

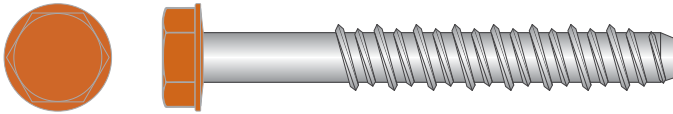

ECKO 15kN Bottom Plate Fixing

| Dia. | Length (mm) | Product Code | Application | PCS / Tub |
|----------|-------------|------------------|-------------------------------------------|-----------|
| M10/15kN | 155 | SBGXM10155TUB-50 | 15kN bottom plate fixing (insulated slab) | 50 |

Includes 50pcs x washer, 1pc x socket driver bit, 1pc x drill bit.

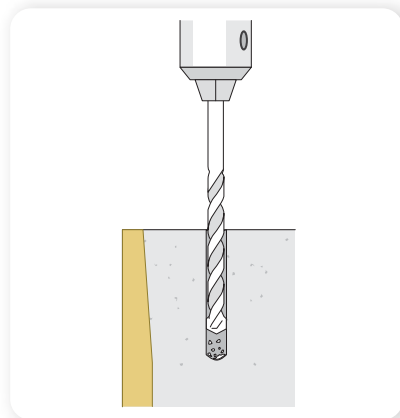

Step 1

Using a 10mm masonry drill bit, drill a hole to the required embedment + 10mm. Ensure that the minimum edge distance (from outside of insulation) of 58mm is adhered too.

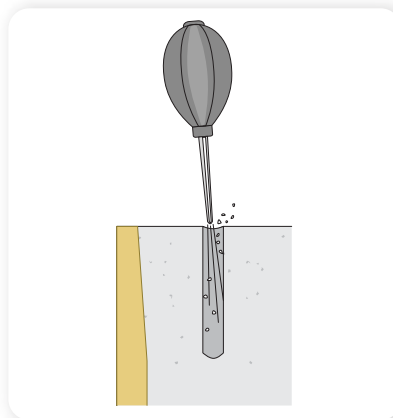

Step 2

Clean dust and debris from hole.

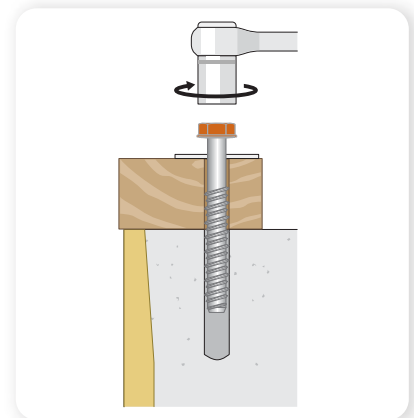

Step 3

Screw in anchor using torque wrench or impact wrench until flange head is firmly secured against washer. **DO NOT OVER-TIGHTEN.**



ECKO M10 x 155mm Screw Bolt (orange head) 90mm bottom plate anchor solution is BRANZ tested (ST18050-01-02). For use with Firth's RibRaft HotEdge® insulation solution for concrete foundations. **Please refer to www.firth.co.nz for installation guide.*

7kN Bottom Plate Fixing Guide

Hot Dip Galvanised

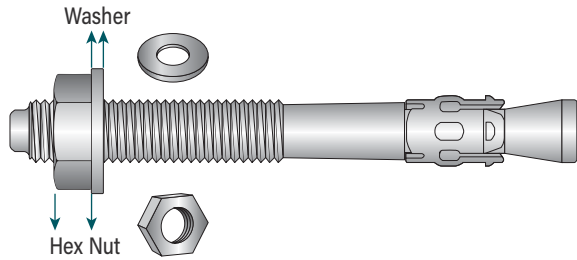

| ECKO 15kN Bottom Plate Fixing | | | | | | |
|-------------------------------|-------------|-----------------|---------------|-----------|------------|-----------------------|
| Dia. | Length (mm) | Product Code | Square Washer | Drill Bit | PCS / Pack | Packaging |
| M12/7kN | 135 | TBGM12135SW-25 | 25 | 1 | 25 | Box / Cardboard |
| | 135 | TBGM12135TUB-50 | 50 | 1 | 50 | Tube / Plastic bucket |

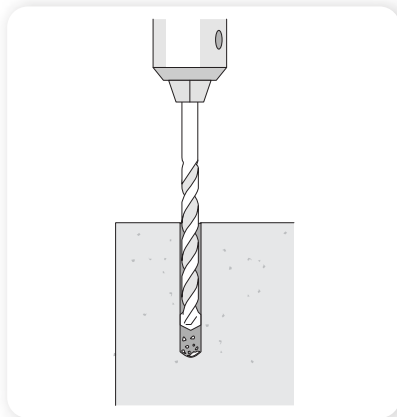

Step 1
Using the correct masonry drill bit, drill a hole to the required embedment +10mm. Ensure that the minimum edge distance of 55mm is adhered to.

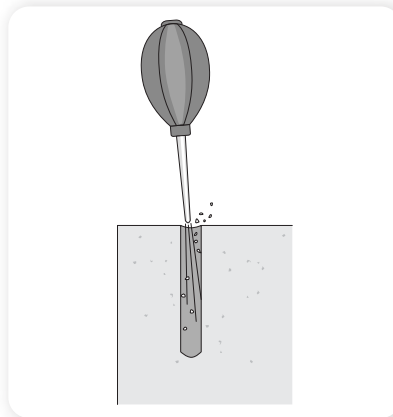

Step 2
Clean dust and debris from hole.

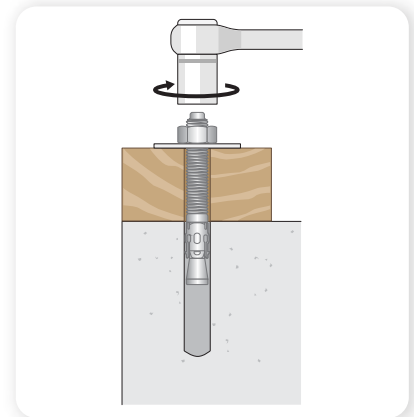

Step 3
Screw in anchor using torque wrench or impact wrench until flange head is firmly secured against washer. DO NOT OVER-TIGHTEN.

